

**ESSENTIAL**

**PBP15-20Q(B)(L) & PBV20QL Series**

# PEDESTRIAN POWER PALLET TRUCK

1.5-2.0 tonnes

**DESIGNED TO DELIVER  
BUILT TO ENDURE**

An economical price for the ESSENTIAL range doesn't mean that there should be any need to compromise on quality or performance. The tough construction of PBP15-20Q(B)(L)(E) & PBV20QL Series models mean they're built to last for years with minimal servicing requirements, but can make a big difference to productivity and efficiency in the warehouse.

## **SPECIFICATIONS**

PBP15QBL  
PBP18QL  
PBP20QBL  
PBP20QL  
PBV20QL



**WHEN  
RELIABILITY IS  
EVERYTHING...**

# ESSENTIAL

## PBP15-20Q(B)(L) & PBV20QL Series

### PEDESTRIAN POWER PALLET TRUCK

1.5-2.0 tonnes



#### BRAKES

- **Electromagnetic braking system** <sup>1) 2) 4)</sup>  
Smooth, steady deceleration and prolonged life of brakes.
- **Parking brake**  
Automatically stops on gradients and ramps
- **High-efficiency regenerative braking** <sup>4)</sup>  
This gives more effective control and reduces brake wear. Kinetic energy from braking charges the battery.

#### DRIVE

- **Powerful AC drive motor**  
Excellent traction, smooth, quiet, controlled operation, extended shift length and lower maintenance requirements.
- **TractionPlus** <sup>2)</sup>  
Suspension system works to continuously increase pressure of the drive wheel. This ensures optimum traction on wet surfaces for better productivity and minimal risk of accidents.

#### ELECTRICAL AND CONTROL SYSTEMS

- **High performance Curtis motor drive controller** <sup>1) 2)</sup>  
This delivers excellent traction control.
- **Battery Discharge Indicator with hour meter** <sup>1) 2) 4)</sup>  
Fitted as standard for battery protection and preventing deep discharge



- **Li-ion battery**  
Fast opportune charging removes the need for extra batteries and allows 24/7 operation. (Option)
- **External charger**  
It's possible to charge the battery onboard.
- **Sideways battery exchange** <sup>1) 2) 3)</sup>  
Battery can be changed out in 10 seconds without the need for additional tools

#### FORKS AND MAST

- **Easy-to-adjust fork leverage** <sup>1)</sup>  
Forks can be adjusted via conveniently located bolts.
- **High-strength tapered forks** <sup>1) 2)</sup>  
Constructed from 6mm manganese steel, tapering makes access to pallets in racks or block stacks is easier, quicker, and safer.
- **Skid runner welded to the forks** <sup>1) 2)</sup>  
Maintenance-free and provides easy entry and exit to a pallet (Option)
- **Pallet entry and exit rollers** <sup>1) 2) 6)</sup>  
Provides extra easy entry and exit to a pallet (Option))

#### FRAME AND BODY

- **Tough construction**  
Truck has been designed and rigorously tested to ensure high stability, rigidity, and protection.
- **Compact design and tight turning radius** <sup>2) 3)</sup>  
Works well in small aisles and narrow spaces.

- **Large diameter plunger cylinder** <sup>3)</sup>  
Low hydraulic system pressure, provides low failure rate and long service life.

#### OPERATOR COMPARTMENT AND CONTROLS

- **Easy-to-operate long tiller arm** <sup>1) 2) 3)</sup>  
Features an ergonomic tiller head with simple controls. Long arm helps to keep the load at a safe distance from the operator to reduce accidents.
- **Creep speed function and tiller-up drive** <sup>1) 2) 3)</sup>  
Both help to maximise safety and control in confined spaces.
- **Emergency reverse safety switch** <sup>1) 2) 4)</sup>  
Button on the end of the tiller head immediately reverses the truck a short way to prevent the operator getting trapped.
- **Multi-function control tiller head**  
Combines the functions of lifting, lowering, forward, backwards, emergency reverse, electric lock, and an information display.
- **PIN code access** <sup>1) 2) 5)</sup>  
Stops unauthorised truck use and keeps you aware of who's operating at all times.



For more information on PBP15-20Q(B)(L) & PBV20QL Series please visit our website



FOOTNOTES:  
1) PBP18-20QL, 2) PBV20QL, 3) PBP15QBL, 4) PBP15-12QBL (Option only on 2.0-tonne models), 5) PBP15-12QBL (Option), 6) PBP15-20QBL

# ESSENTIAL

## PBP15-20Q(B)(L) & PBV20QL Series

### PEDESTRIAN POWER PALLET TRUCK

1.5-2.0 tonnes

#### OTHER FEATURES

- **Battery heating system** <sup>1)2)</sup>  
Used in cold environments down as low as 1°.
- **Side castor wheels** <sup>1)2)5)</sup>  
Improves stability.
- **Load check scale** <sup>3)</sup>  
Helps driver to identify overweight loads.
- **Electrical cut off of lifting at max height** <sup>3)</sup>  
Protects hydraulic system, cylinder, and electrical components.
- **Printer on scale** <sup>4)</sup>  
This documents individual weighings so operators don't have to do this by hand.
- **Li-ion battery trolley (twin battery station)** <sup>2)</sup>  
This helps with battery exchange



#### FOOTNOTES:

1) PBP18-20QL, 2) PBV20QL, 3) PBP15-QBL, PBP15QBE, 4) PBP15-12QBL (Option only on 2.0-tonne models), 5) PBP15-12QBL (Option)

Continuing improvement may lead to changes in these specifications

For more information  
on PBP15-20Q(B)(L) &  
PBV20QL Series please  
visit our website



[mft2.eu/essbpbpvq](http://mft2.eu/essbpbpvq)



# ESSENTIAL LI-ION BATTERY SYSTEMS

## MAKE YOUR FORKLIFT GO EVEN FURTHER

**Tried, tested and proven in the field, lead-acid batteries have been the long-standing choice for companies employing electric lift trucks. However, with long charging times, demanding maintenance requirements, the need for extra batteries, and high risk of operator misuse, day-to-day use can be a challenge.**

Fortunately, there's a new battery system on the block: Li-ion from Mitsubishi Forklift Trucks.

Designed to meet your business' demands — including multi-shift (24/7) operations — without the need for spare batteries, our high-performance Li-ion battery system is up to 30% more efficient than lead-acid counterparts. Plus, it's virtually error-proof, thanks to its ultra-low-maintenance design which prevents cell damage.

- **Gas-emission free**  
No need for air ventilation.

- **Exceptional high battery and charger efficiency**  
State-of-the-art technology delivers up to 30% more power efficiency than lead-acid batteries.
- **Maintenance-free design**  
No need for daily checks and water re-fills. This reduces the risk of operators damaging cells and reducing their lifetime. Needs a full charge each week to activate cell balancing.
- **No need for spare batteries or charging room**  
You can save both space and costs in multi-shift applications, maximising profitability.
- **Quick charge capabilities**  
Just 15 minutes is all your battery needs to keep your truck going for a few more hours. It only takes 1 to 2 hours to fully charge a completely discharged battery.

- **Higher sustained voltage**  
This gives more consistent lifting and driving performance — particularly noticeable towards the end of a shift.
- **Multiple safety features**  
This includes circuit protection, deep-discharge and overcharge protection, and individual cell temperature and voltage monitoring.
- **On-the-go performance and monitoring**  
The system's integrated monitoring system has an easy-to-read display unit.
- **Wide choice of battery and charger capacities**  
The most suitable power supply can be matched to the exact requirements of a specific application.



**Clean Li-ion batteries are ideal for sensitive environments such as those in the food or packaging industries.**

**Fully integrated Li-ion battery**

Features a sophisticated CANbus communication and an automatic ON/OFF synchronization between battery and truck. Battery level, notifications and alarms are integrated into the truck display, to secure clear and easy overview for the truck operator.

**For more information on Li-ion please visit our website**



Li-ion battery option is available in selected regions. Continuing improvement may lead to changes in these specifications

# VDI - PERFORMANCE & DIMENSIONS

CHARACTERISTICS					
1.1	Manufacturer			Mitsubishi Forklift Trucks	Mitsubishi Forklift Trucks
1.2	Manufacturer's model designation			PBP15QBL	PBP20QBL
1.3	Power source			Battery	Battery
1.4	Operator type			Pedestrian	Pedestrian
1.5	Load capacity	Q	kg	1500	2000
1.6	Load center distance	c	mm	600	600
1.8	Load wheel axle to fork face (forks lowered)	x	mm	950/1020	950/1020
1.9	Wheelbase	y	mm	1195/1265	1195/1265
WEIGHT					
2.1b	Truck weight without load, with maximum battery weight			135	140
2.2	Axle loadings with nominal load & maximum battery weight, drive / load side			665 / 970	870 / 1270
2.3	Axle loadings without load & with maximum battery weight, drive / load side			95 / 40	98 / 42
WHEELS, DRIVE TRAIN					
3.1	Tyres: PT = Power Thane, Vul = Vulkollan, P = Polyurethane, N = Nylon, R = Rubber drive / load side			P	P
3.2	Tyre dimensions, drive side	mm		210 x 70	210 x 70
3.3	Tyre dimensions, load side	mm		80x70 (Tandem) 80x93 (Single)	80x70 (Tandem) 80x93 (Single)
3.4	Castor wheel dimensions (diameter x width)	mm		60x35 (Option)	60x35 (Option)
3.5	Number of wheels, load / drive side (x = driven)			1x2(	1x2(
3.6	Track width (center of tyres), drive side	b10	mm	460	460
3.7	Track width (center of tyres), load side	b11	mm	390/520	390/520
DIMENSIONS					
4.4	Lift height	h3	mm	110	110
4.9	Height of tiller arm / steering console (min./max.)	h7	mm	650/1135	650/1135
4.15	Fork height, fully lowered	h13	mm	80	80
4.19	Overall length	l1	mm	1545	1545
4.20	Length to fork face	l2	mm	395	395
4.21	Overall width	b1/b2	mm	550	550
4.22	Fork dimensions (thickness, width, length)	s/e/l	mm	70/160/1150	70/160/1150
4.25	Outside width over forks (minimum / maximum)	b5	mm	550	550
4.32	Ground clearance at center of wheelbase, (forks lowered)	m2	mm	27	27
4.33a	Working aisle width (Ast) with 1000 x 1200 mm pallets, load crosswise	Ast	mm	2150	2150
4.33b	Working aisle width (Ast3) with 1000 x 1200 mm pallets, load crosswise	Ast3	mm		
4.33c	Working aisle width (Ast) with 1000 x 1200 mm pallets, load crosswise, platform up/down	Ast	mm		
4.34a	Working aisle width (Ast) with 800 x 1200 mm pallets, load lengthwise	Ast	mm	2015	2015
4.34b	Working aisle width (Ast3) with 800 x 1200 mm pallets, load lengthwise	Ast3	mm		
4.35c	Working aisle width (Ast) with 800 x 1200 mm pallets, load lengthwise, platform up/down	Ast	mm		
4.35	Turning radius	Wa	mm	1345	1345
PERFORMANCE					
5.1	Travel speed, with / without load	km/h		4.3/4.5	4.6/4.8
5.2	Lifting speed, with / without load	m/s		0.025/0.030	0.020/0.025
5.3	Lowering speed, with / without load	%		0.035/0.025	0.035/0.025
5.8	Maximum gradeability with / without load	s		5 / 20	6 / 20
5.10	Service brakes (mechanical / hydraulic / electric / pneumatic)				Electric
ELECTRIC MOTORS					
6.1	Drive motor capacity (60 min. short duty)	kW		0.75	1
6.2	Lift motor output at 15% duty factor	kW		0.8	0.8
6.4	Battery voltage/capacity at 5-hour discharge	V/Ah		24 / 25	48 / 20
6.5	Battery weight	kg		9	10
6.6b	Energy consumption according to VDI 60 cycle	kWh / h			
MISCELLANEOUS					
8.1	Type of drive control			Stepless	Stepless
10.7	Level of noise at the ear level of the driver according to EN 12 053:2001 and EN ISO 4871 in work LpAZ	dB (A)			
10.7.1	Level of noise at the ear level of the driver according to EN 12 053:2001 and EN ISO 4871, drive/lift/idle LpAZ	dB (A)		70	70
10.7.3	Hand-arm vibration (EN 13 059:2002)				

## ESSENTIAL PBP15 - 20QBL PEDESTRIAN POWER PALLET TRUCK

1.5 - 2.0 tonnes

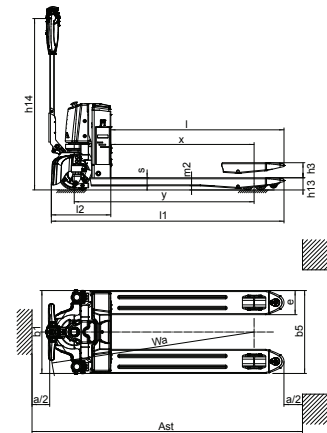

# VDI - PERFORMANCE & DIMENSIONS

CHARACTERISTICS				Mitsubishi Forklift Trucks	Mitsubishi Forklift Trucks	Mitsubishi Forklift Trucks
1.1	Manufacturer			PBP18QL	PBP20QL	PBV20QL
1.2	Manufacturer's model designation			Battery	Battery	Battery
1.3	Power source			Pedestrian	Pedestrian	Pedestrian / stand on
1.4	Operator type					
1.5	Load capacity	Q	kg	1800	2000	2000
1.6	Load center distance	c	mm	600	600	600
1.8	Load wheel axle to fork face (forks lowered)	x	mm	987	964	964
1.9	Wheelbase	y	mm	1330	1359	1261
WEIGHT						
2.1b	Truck weight without load, with maximum battery weight		kg	420	620	
2.2	Axle loadings with nominal load & maximum battery weight, drive / load side		kg	992 / 1228	1170 / 1450	1300 / 1410
2.3	Axle loadings without load & with maximum battery weight, drive / load side		kg	324 / 496	470 / 150	600 / 110
WHEELS, DRIVE TRAIN						
3.1	Tyres: PT = Power Thane, Vul = Vulkollan, P = Polyurethane, N = Nylon, R = Rubber drive / load side			P	P	P / P
3.2	Tyre dimensions, drive side		mm	230 x 100	250 x 70	250 x 80
3.3	Tyre dimensions, load side		mm	82 x 98 / 82 x 70	82x126 (Single) 82x98 (Tandem)	82 x 126(Single) 82 x 988Tandem
3.4	Castor wheel dimensions (diameter x width)		mm	90 x 40	127 x 57	127 x 57
3.5	Number of wheels, load / drive side (x = driven)			1x + 2/2 (	1x + 2/2 (	1x + 2/2 (
3.6	Track width (center of tyres), drive side	b10	mm	478	510	537
3.7	Track width (center of tyres), load side	b11	mm	375	370	340 / 370 / 470 / 505
DIMENSIONS						
4.4	Lift height	h3	mm	120	120	120
4.9	Height of tiller arm / steering console (min./max.)	h7	mm	750 / 1250	530 / 1230	1050 / 1450
4.15	Fork height, fully lowered	h13	mm	82	82	82
4.19	Overall length	l1	mm	1666	1705	1760
4.20	Length to fork face	l2	mm	516	555	610 / 1072
4.21	Overall width	b1/b2	mm	710	775	775
4.22	Fork dimensions (thickness, width, length)	s/e/l	mm	55 / 160 / 1150	54 x 180 x 1150	54 / 180 / 1150
4.25	Outside width over forks (minimum / maximum)	b5	mm	550 / 685	520 / 550 / 685	520 / 550 / 650 / 685
4.32	Ground clearance at center of wheelbase, (forks lowered)	m2	mm	27	28	28
4.33a	Working aisle width (Ast) with 1000 x 1200 mm pallets, load crosswise	Ast	mm	2302	2320	
4.33b	Working aisle width (Ast3) with 1000 x 1200 mm pallets, load crosswise	Ast3	mm			
4.33c	Working aisle width (Ast) with 1000 x 1200 mm pallets, load crosswise, platform up/down	Ast	mm			1960 / 2422
4.34a	Working aisle width (Ast) with 800 x 1200 mm pallets, load lengthwise	Ast	mm	2156	2180	
4.34b	Working aisle width (Ast3) with 800 x 1200 mm pallets, load lengthwise	Ast3	mm			
4.35c	Working aisle width (Ast) with 800 x 1200 mm pallets, load lengthwise, platform up/down	Ast	mm			2010 / 2472
4.35	Turning radius	Wa	mm	1504	1520	1600
PERFORMANCE						
5.1	Travel speed, with / without load		km/h	5.8 / 6	5.5 / 5.6	7 / 7.1
5.2	Lifting speed, with / without load		m/s	0.03 / 0.038	0.025 / 0.035	0.025 / 0.035
5.3	Lowering speed, with / without load		%	0.04 / 0.036	0.035 / 0.030	0.035 / 0.030
5.8	Maximum gradeability with / without load		s	8 / 20	8 / 20	8 / 20
5.10	Service brakes (mechanical / hydraulic / electric / pneumatic)			Electric	Electric	Electric
ELECTRIC MOTORS						
6.1	Drive motor capacity (60 min. short duty)		kW	1.2	1.2	1.5
6.2	Lift motor output at 15% duty factor		kW	0.8	1.2	1.2
6.4	Battery voltage/capacity at 5-hour discharge		V/Ah	24 / 100	24 / 125	24 / 125
6.5	Battery weight		kg	55	60	60
6.6b	Energy consumption according to VDI 60 cycle		kWh / h			
MISCELLANEOUS						
8.1	Type of drive control			Stepless	Stepless	Stepless
10.7	Level of noise at the ear level of the driver according to EN 12 053:2001 and EN ISO 4871 in work LpAZ		dB (A)			
10.7.1	Level of noise at the ear level of the driver according to EN 12 053:2001 and EN ISO 4871, drive/lift/idle LpAZ		dB (A)	70	70	70
10.7.3	Hand-arm vibration (EN 13 059:2002)			<2.5		<2.5

**ESSENTIAL**

## PBP18QL - 20QL & PBV20QL PEDESTRIAN POWER PALLET TRUCK

1.8 - 2.0 tonnes

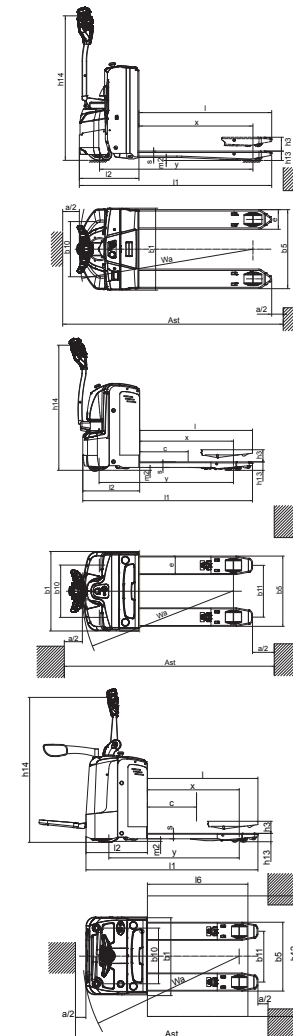

# WHEN RELIABILITY IS EVERYTHING...



**ESSENTIAL**  
SIMPLE. RELIABLE.  
ECONOMICAL.

High quality, low cost.

The ESSENTIAL range of warehouse products is ideal for low- to medium-intensity operations in a huge number of different applications. The tough, low-maintenance designs offer excellent value for money.

Like any product bearing the Mitsubishi Forklift Trucks name, our materials handling equipment benefits from the tremendous heritage, huge resources and cutting-edge technology of one of the world's largest corporations – Mitsubishi Heavy Industries Group.

Engineering spacecraft, jet planes, power plants and more, MHI specialises in those technologies where performance, dependability and superiority decide your success or failure...

So when we promise you quality, reliability and value for money, you know it's a guarantee we have the power to deliver.

That's why every model in our award-winning and comprehensive range of lift trucks and warehouse equipment is built to a high specification – to ensure it keeps working for you. Day after day. Year after year. Whatever the job. Whatever the conditions.

## YOU'LL NEVER WORK ALONE

As your local authorised dealer, we are here to keep your trucks working – through our extensive experience, our technical excellence and our commitment to customer care.

We are your local experts, backed by efficient channels to the entire organisation of Mitsubishi Forklift Trucks.

No matter where you are, we are close by – with the capability to meet your needs.

Discover how Mitsubishi Forklift Trucks give you more from your local authorised distributor or when you visit our website [www.mitforklift.com](http://www.mitforklift.com)

Performance specifications may vary depending on standard manufacturing tolerances, vehicle condition, types of tyres, floor or surface conditions, applications or operating environment. Trucks may be shown with non-standard options. Specific performance requirements and locally available configurations should be discussed with your distributor of Mitsubishi forklift trucks. We follow a policy of continual product improvement. For this reason, some materials, options and specifications could change without notice.

[info@mitforklift.com](mailto:info@mitforklift.com)

WESM2465 © 2024 MLE

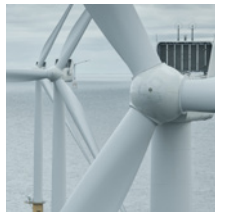

Mitsubishi Logisnext Europe B.V.  
Hefbrugweg 77, 1332 AM Almere  
The Netherlands  
Tel: +31 (0)36 5494 411



[mft2.eu/fb](http://mft2.eu/fb)



[mft2.eu/apps](http://mft2.eu/apps)



[mft2.eu/youtube](http://mft2.eu/youtube)



[mft2.eu/facebook](http://mft2.eu/facebook)

